

Infinity®

IRS SERIES V SYSTEM

Owner's Manual
Infinity Reference Standard
Series V



(P/N .930...3095)

Table of Contents

<i>Before You Begin to Assemble Your IRS V Speaker System.....</i>	<i>1</i>
<i>Unpacking the Woofer Towers.....</i>	<i>4</i>
<i>Unpacking/Assembling the Midrange/Tweeter Sections.....</i>	<i>5</i>
<i>Connecting the Midrange/Tweeter Sections' Drivers.....</i>	<i>8</i>
<i>Input Impedance Matching.....</i>	<i>9</i>
<i>Connecting the System.....</i>	<i>11</i>
<i>Before Operating the System: A Word About Absolute Phase.....</i>	<i>15</i>
<i>Operating the System.....</i>	<i>18</i>
<i>Adjusting the Sound.....</i>	<i>19</i>
<i>The Electronic Crossover Unit.....</i>	<i>20</i>
<i>Some Features of the IRS V Speaker System.....</i>	<i>23</i>
<i>Care of the Enclosures.....</i>	<i>25</i>
<i>System Log Sheet.....</i>	<i>26</i>

Before You Begin to Assemble Your Infinity Reference Standard Series V...

Please take the time to familiarize yourself with the unpacking and installation procedures contained in this manual.

Installation of the system will require the following tools and miscellaneous materials:

- A claw hammer or needle-nosed pliers (to open the crates)
- A medium (#2) phillips screwdriver
- A large (#6) flatblade screwdriver
- A 7/16" nutdriver or deep-socket
- A small soldering iron (approximately 20 watts) (use the solder included in the Accessory Kit)
- A crimping tool or similar type of pliers
- A few large, soft towels or blankets (to protect the speakers)

It will take at least two physically sturdy individuals to unpack and assemble your Infinity Reference Standard Series V. If you are having your system installed by persons other than yourself, be certain they are completely familiar with all of the assembly procedures and precautions prior to beginning the assembly.

The Infinity Reference Standard Series V performs best when set up in a large rectangular room. The recommended starting position for the system is illustrated in figure 1; from there some experimenting will be necessary to achieve the best possible results, as discussed further along in this manual.

Figure 1: Suggested Starting Locations

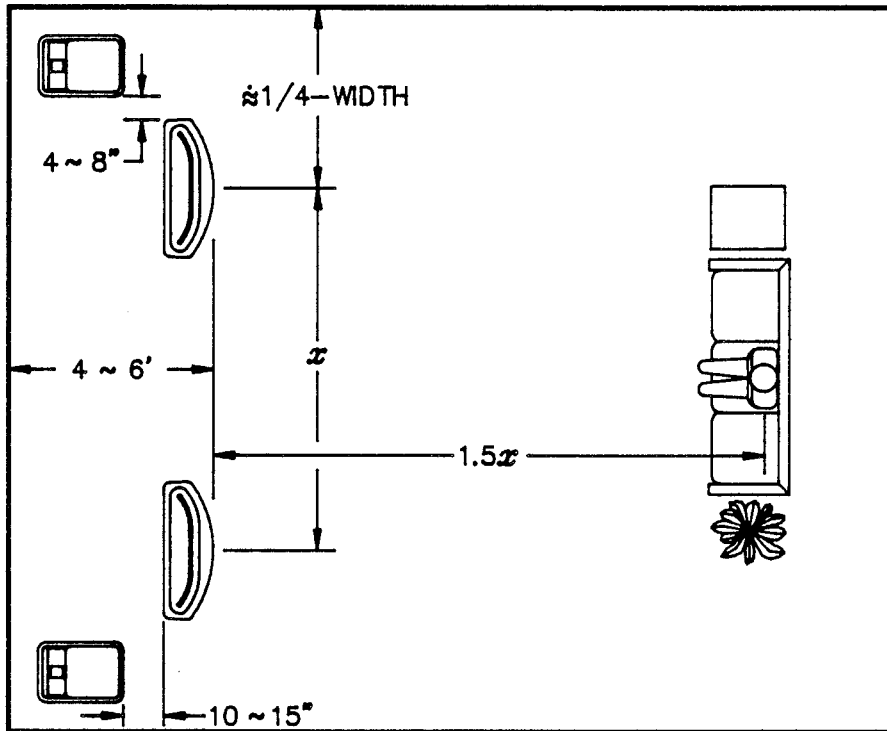

When moving the crates, try not to tilt them too far to either side, and under no circumstances are the crates to be placed on their tops or sides, nor stood on their ends.

Once emptied, the shipping crates should be stored (away from excessive moisture) since they will prove invaluable if you should ever need to transport your Infinity Reference Standard speaker system.

In order to minimize signal crosstalk, all of the connecting cables (woofer tower control voltages, low-frequency signals, and midrange/tweeter speaker leads) should be kept separate at least two or three inches from one another. Also, when it is necessary for cables to cross one another, such crossings should be done at ninety-degree angles (see figure 2).

Figure 2: Lead Layouts

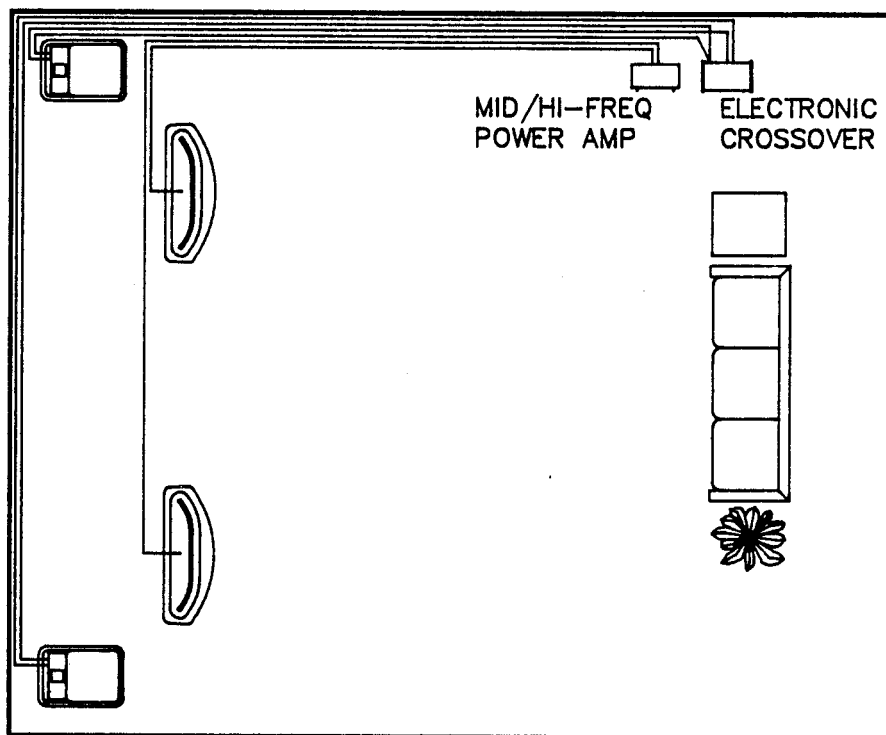

The Infinity Reference Standard Series V speaker system is shipped in four separate crates:

- Two large (8'x3'x2') crates, each one containing one woofer tower assembly;

- One mid-sized (7.5'x2'x1.5') crate containing the curved "wings" and flat center-sections of the midrange/tweeter assemblies, and the mid/tweeter section assembly fixture;

- One small (4'x2'x2') crate containing the fiberglass top caps and bases of the midrange/tweeter assemblies, the connecting cables for the woofer towers, the electronic crossover unit and the Accessory Kit.

Unpacking the Woofer Towers:

If at all possible, the woofer towers should be uncrated in the proposed listening area, near their new locations. This will reduce not only the chances of damaging their bases but also the possibilities of personal injury which might be incurred if the very large and heavy towers are not handled correctly.

It will not matter which woofer tower is used on the left or right channel since they are both acoustically and cosmetically identical. It will help, however, to position the crates with the ends marked "TOWER BASE THIS END" nearest to the proposed locations.

Remove all of the clamps from the bottom edges of one of the woofer crates. Follow the instructions printed on the lid of the small crate.

With a person at each crate end, lift straight up about three feet until the crate clears the woofer tower (see figure 3). Now set the crate aside.

Figure 3: Lift Woofer Crate Until It Clears the Woofer Tower

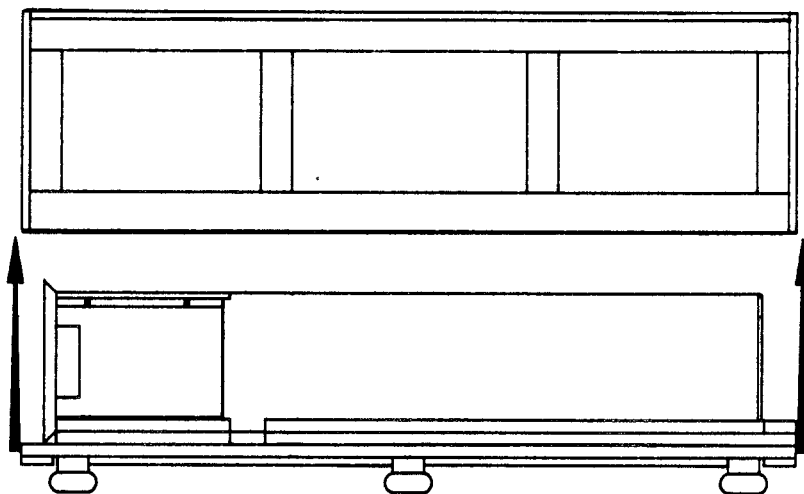

Remove the plastic wrap from the woofer tower, then carefully slide the tower about 14-18" towards its base end. (The tower weighs over 300 pounds, so be sure to handle it properly.)

Place a blanket or large towel between the tower and the edge of the crate for protection. (If working on a hard surface, the blanket should also be positioned under the tower's base while being erected and moved into position.) It will now take at least two strong people to raise the tower to the vertical position. (Be sure to avoid straining yourselves while lifting.)

Once vertical, remove the plastic from the tower and "walk" it into position by means of a series of short twists and turns towards the desired location.

Repeat this procedure for the second woofer tower.

Unpacking and Assembling the Midrange/Tweeter Sections:

Remove all of the clamps from the top edges of the mid-sized crate (following the instructions printed on the lid of the small crate); lift off the lid and set it aside. If necessary, open the small crate and set its lid aside.

Packed inside the mid-sized crate are the pieces of a fixture which will facilitate the assembling of the midrange/tweeter section. Remove the four wooden pieces and the hardware from their plastic wrap and assemble as shown in figure 4.

Figure 4: Assembling the Assembly Fixture

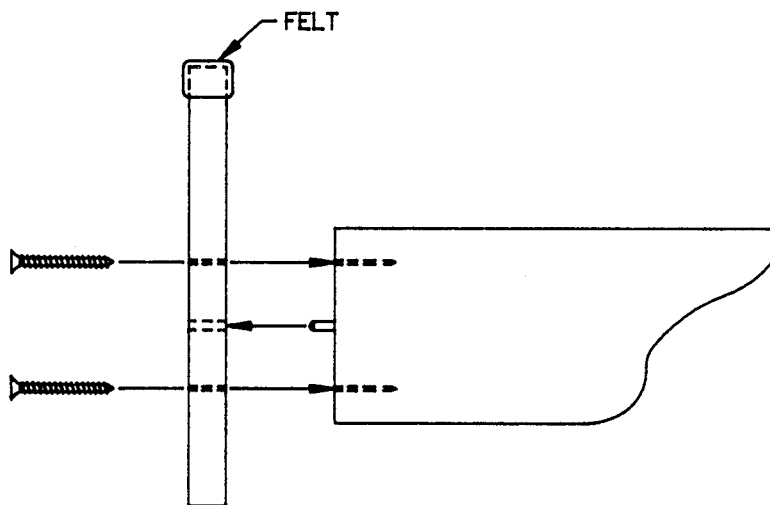

Each of the speaker sections in the mid-sized crate weigh about 40 pounds, so remove them carefully from the crate, unwrap them and lean them against the wall, or lay them carefully on the floor. DO NOT set the two flat center-sections down on their wiring!

Inside the small crate are the top caps and bases for the midrange/tweeter sections: remove them carefully, unwrap them, and set them aside on a smooth surface. Take care not to scratch or otherwise damage them in the process.

Also inside the small crate is the Accessory Kit. The majority of the contents of the kit will be discussed later on; for now you will only need the sixteen large screws (eight each 1/4-20 x 1" pan head and eight each 1/4-20 x 1" flat head) from the kit.

Refer to the illustration in figure 5 on the next page for the following steps:

Set the assembly fixture in front of the proposed location for the LEFT channel midrange/tweeter section and lay a towel or blanket over it for added protection. Gently lay the flat section labeled "LEFT" onto the fixture, wiring-side-up, with the label at the end AWAY from the speaker's base location.

Locate the curved section labeled "LEFT SIDE LEFT WING" and gently lay it on the side of the fixture to the RIGHT of the flat section, with its labeled edge facing the edge of the flat piece. (Don't let this confuse you: you're viewing the speaker from the back, so the left and right curved sections appear to be reversed.) Align the holes in the edge of the curved piece with the dowels in the edge of the flat piece and gently slide the pieces together.

Locate the curved section labeled "LEFT SIDE RIGHT WING" and gently lay it in place in the same manner.

Place one of the fiberglass bases at the end of the midrange/tweeter sections, opposite the labeled end of the flat section. Line up the curved slot in the base with the curve of the midrange/tweeter sections and push the base into place.

Insert four of the pan-head screws through the holes in the base and into the threaded inserts along the bottom edges of the midrange/tweeter sections' curved wings. Tighten the screws firmly and evenly, making sure that the midrange/tweeter sections are fully seated in the base's slot.

Position one of the fiberglass top caps and hold it in place at the labeled end of the midrange/tweeter sections. Insert four of the flat-head screws through the holes in the top cap and into the threaded inserts along the top of the midrange/tweeter sections. Tighten the screws firmly but avoid overtightening as this may crack the top cap.

With one person at each side, carefully lift the midrange/tweeter assembly into an upright position. A towel or blanket placed between the mid/tweeter base and the floor will help prevent damage to the base's finish.

Repeat the above procedures for the remaining sections of the RIGHT midrange/tweeter assembly.

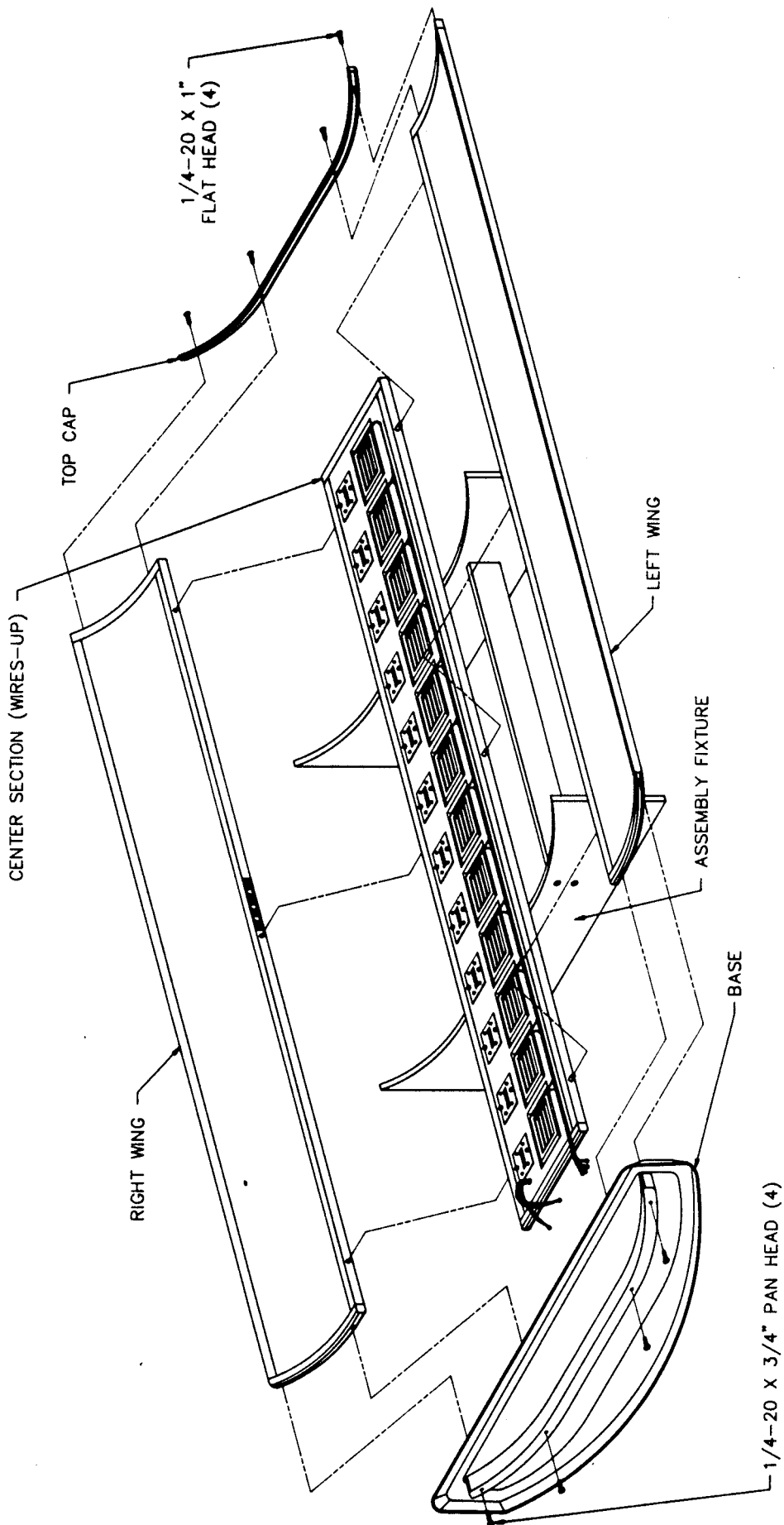
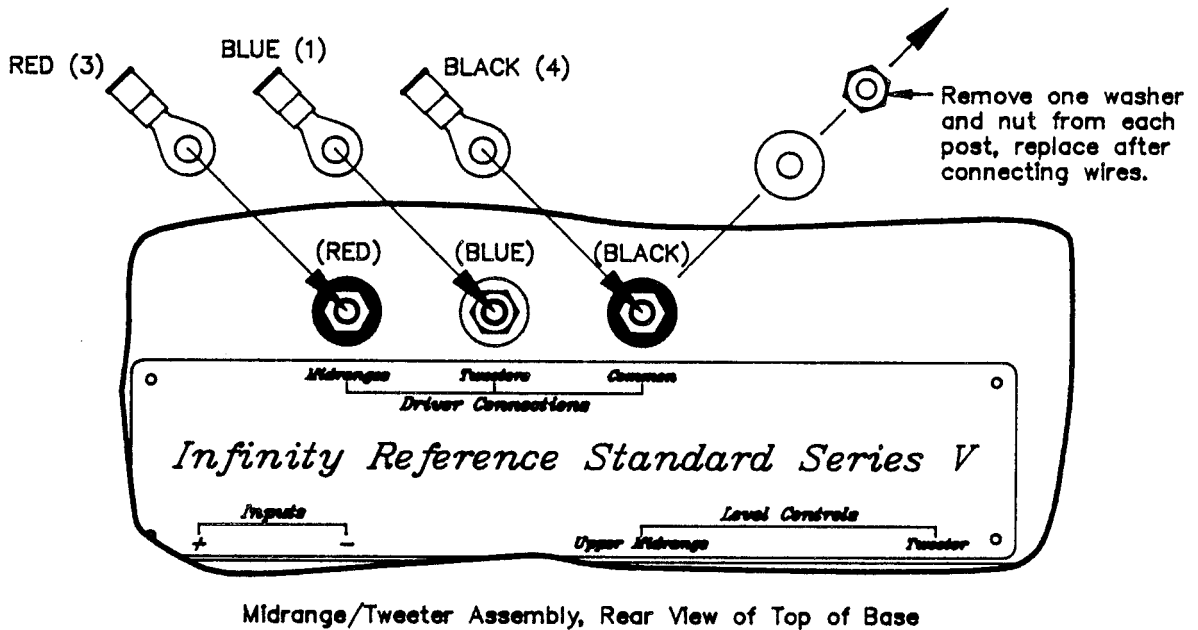

Figure 5: Midrange/Tweeter Assembly (Exploded View)

Connecting the Midrange/Tweeter Sections' Drivers:

From the rear of the midrange/tweeter assembly, remove the top 7/16" hex-nut and flat washer from each of the three "Driver Connection" posts and set them aside (see figure 6).

Figure 6: Driver Input Connections



Connect the wiring as follows:

The three ring terminals with the red sleeving go to the post with the red base;

The ring terminal with the blue sleeving goes to the post with the blue base;

The four ring terminals with the black sleeving go to the post with the black base.

Replace the washers and nuts; tighten firmly.

Repeat for the above procedures for the other midrange/tweeter assembly.

Input Impedance Matching:

Contained in the Accessory Kit are two pale blue boxes, along with several resistors, capacitors, and other items which are to be used for matching the input impedance of your mid/high-frequency power amplifier(s) to that of the Infinity Reference Standard Series V. This is not difficult, if you follow the instructions and chart listed below. It does not require modifications to anything other than the two small boxes provided in the Accessory Kit, and that will require nothing more than the use of a screwdriver and a soldering iron.

The amplifier(s) you choose to power the midrange/tweeter assemblies should be rated somewhere between 75 to 400 watts-per-channel into four ohms. It will be necessary to determine the input impedance of the amplifier(s) in order to choose the proper combination of components for the impedance matching devices in the Accessory Kit. This information should be in the amp's operating instructions; if not, a call to your dealer or even the manufacturer may be necessary.

Open each of the two blue boxes with the screwdriver provided in the accessory kit. Inside each of the boxes you will see two small (0.01uF) WonderCaps(tm), in parallel, between the female RCA jack (the box's input) and the male RCA plug (its output). From this point additional components will be added, using the solder supplied in the kit.

After determining your amplifier's input impedance, refer to the chart on the next page to see which components you will need to solder in place in the two blue boxes. Figure 7 illustrates proper component orientation.

C = The capacitance in the box (uF) (input "+" to output "+")

R_{in} = The mid-high frequency amplifier's input resistance (kΩ)

R_{sh} = Resistor to be soldered across male plug in box (kΩ)

R_{eq} = Parallel combination of R_{in} and R_{sh} (kΩ)

R _{in}	R _{sh} *	R _{eq}	C (uF) **
1MEG	124K	109.0K	0.02 (two 0.01uF in parallel)
500K	140K	(same)	(same)
100K	∞	(same)	(same: cutoff freq. would be 10% high)
100K	267K	72.67K	0.03 (three 0.01uF in parallel)
80K	787K	(same)	(same)
75K	2.32M	(same)	(same)
50K	∞	54.5K	0.04 (four 0.01uF in parallel; cutoff=10% high)
50K	340K	43.6K	0.05 (five 0.01uF in parallel)
33K	∞	36.34K	0.06 (six 0.01uF in parallel; cutoff=10% high)
33K	49.9K	19.82K	0.11 (0.1 and 0.01uF in parallel)
22K	200K	(same)	(same)
20K	2.21M	(same)	(same)
10K	1.1M	9.91K	0.22 (two 0.1 and 0.01uF in parallel)

To figure other combinations, choose C such that R_{eq} is less than R_{in}. Then R_{sh} in parallel with R_{in} will equal R_{eq}.

$$R_{eq} = \frac{1000}{2\pi(73.0)C} \quad R_{sh} = \frac{(R_{in})(R_{eq})}{R_{in} - R_{eq}} \quad (R \text{ in } k\Omega, C \text{ in } \mu F)$$

Load on preamp above 200-300Hz: $R_{eq} = \frac{(R_{sh})(R_{in})}{R_{sh} + R_{in}}$

±1% 1/4~1/2-watt

**NOTE: The capacitors supplied in the accessory kit are directional and must be installed so that the current flows through them in the same direction as the printing on their casings, as shown below in figure 7.

Figure 7: Impedance Matching Unit Component Orientation

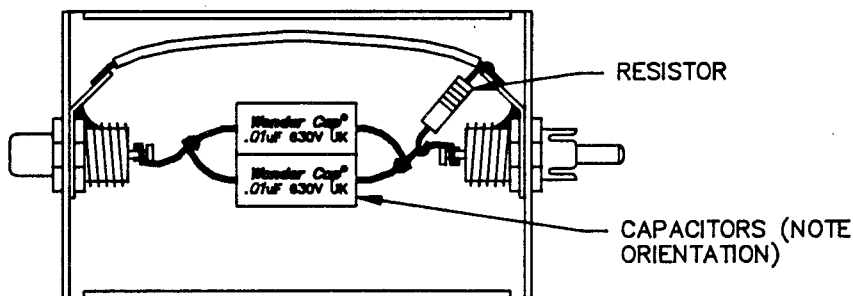

Impedance Matching Unit, Cover Removed

Connecting the System:

In order to obtain the level of excellence of which the Infinity Reference Standard Series V is capable, use only the highest-quality high-end audio components, and choose only the highest-quality audio interconnecting cables and speaker cables for all connections. (Infinity has supplied a pair of interconnects for the woofer towers; your audio dealer can make recommendations as to which cables are best suited for the rest of your system.) Remember that inferior cables will prevent your system from reaching optimum performance.

Unpack the Infinity Reference Standard Series V electronic crossover unit and place it near the preamp which will be used with the system. At this point, all components are to be turned off, with their power cords unplugged.

Connect the OUTPUTS of your preamp to the INPUT jacks of the Infinity Reference Standard Series V electronic crossover (see figure 8-A).

Connect the two impedance matching boxes (with the proper combination of components) to the INPUT jacks of the amplifier(s) you will be using to power the midrange/tweeter assemblies. (See figure 8-B).

NOTE: It may be that the design or placement of your amplifier(s) will not allow the boxes to be connected directly to their input jacks. For this reason you will find a pair of short RCA-type interconnecting cables (male-to-female) in the Accessory Kit. Plug one end of the cables into the input jacks of your amplifier, then plug the impedance matching boxes into the other ends of the cables. (Please use both cables, one per channel, even if only one channel requires it. This will maintain precise symmetry between channels that would be compromised if one channel used the extension while the other did not.)

Connect either pair of the HIGH PASS output jacks on the back of the electronic crossover unit to the female jacks of the impedance matching devices (already connected to your midrange/tweeter amplifier) (see figure 8-C). For optimum results the lengths of each of these cables should not exceed six feet.

Figure 8: Connecting the Mid/High Freq. Circuits

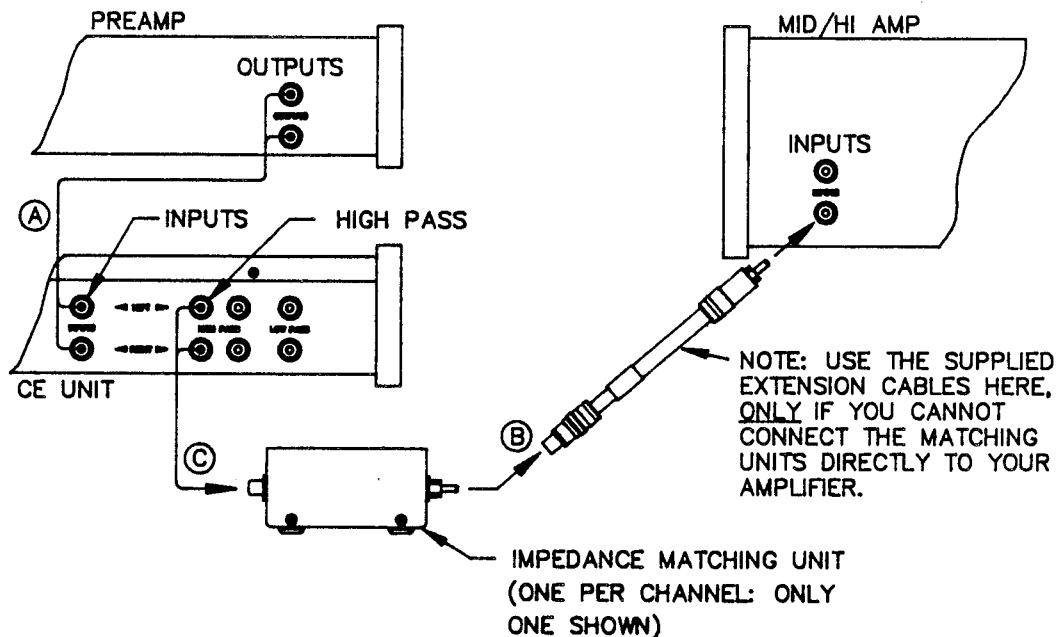

Uncoil each of the supplied cables which have the 3-pin XLR connectors at each end. (These are the cables which supply the woofer tower amplifiers with their "remote turn-on" voltage signal.) Connect one end of one of the cables to the left-channel CONTROL VOLTAGE OUTPUT jack on the electronic crossover unit; connect the other end to the similar jack on the back of the left-channel woofer tower's amplifier. (See figure 9-A.) Repeat for the right channel.

Uncoil each of the supplied cables which have the RCA-type connectors at each end. (These will carry the pre-amplified low-frequency signals to the woofer towers.) These cables are directional and must be installed so that the arrows printed on them point towards the woofer tower amplifiers (not the electronic crossover unit!). Connect one end of one of the cables to the left channel LOW PASS jack on the electronic crossover unit; connect the alternate end to the similar jack on the back of the left-channel woofer tower's amplifier. (See figure 9-B.) Repeat for the right channel.

NOTE: The connectors on these cables have sliding outer sleeves to insure a good connection to the jacks; engage these sleeves after connections are made.

Figure 9: Connecting the Low Freq. Circuits

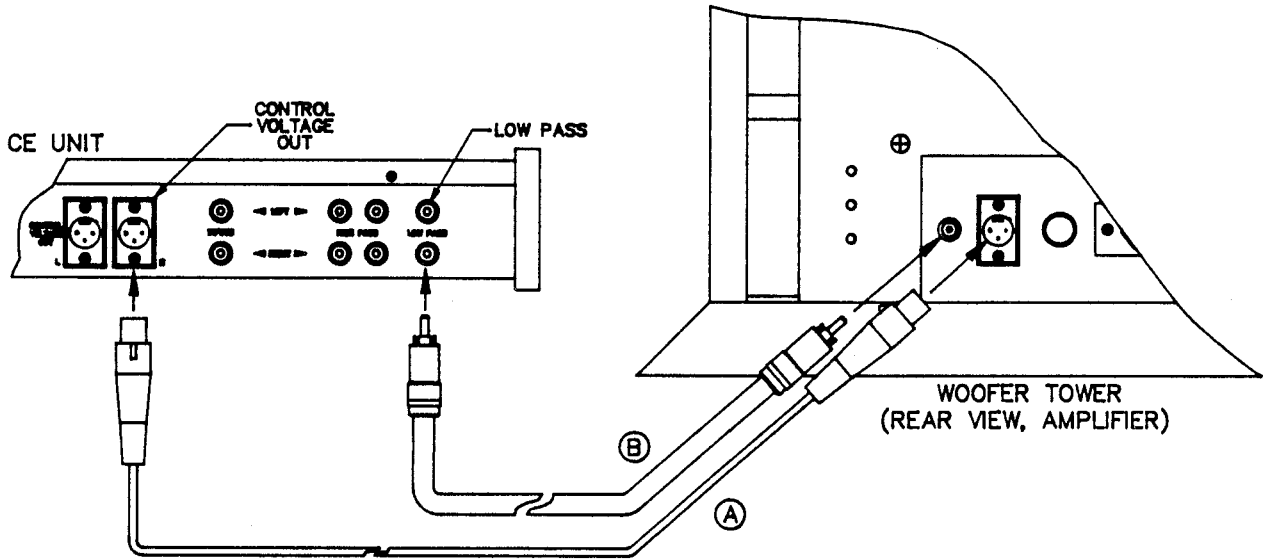

Connect an appropriate length of heavy-gauge (#14 or larger) twin-lead speaker cable to the SPEAKER OUTPUT connectors of the amplifier(s) which you will be using to power the midrange/tweeter sections.

Strip about 1/4" of insulation from the alternate ends of the speaker cables. Twist the strands of each cable and tin with some of the solder provided in the accessory kit.

Each of the input posts of the midrange/tweeter sections already have three large ring terminals connected to them. (Two of these should be removed and kept for future use.) Insert the POSITIVE("+") lead of the left-channel amplifier's speaker output into one of the ring terminals connected to the "+" input post; crimp the lug and carefully solder the connection using the solder provided. (See figure 10.) Repeat for the remaining terminals; tighten securely.

Figure 10: Connecting the Midrange/Tweeter Assembly Inputs

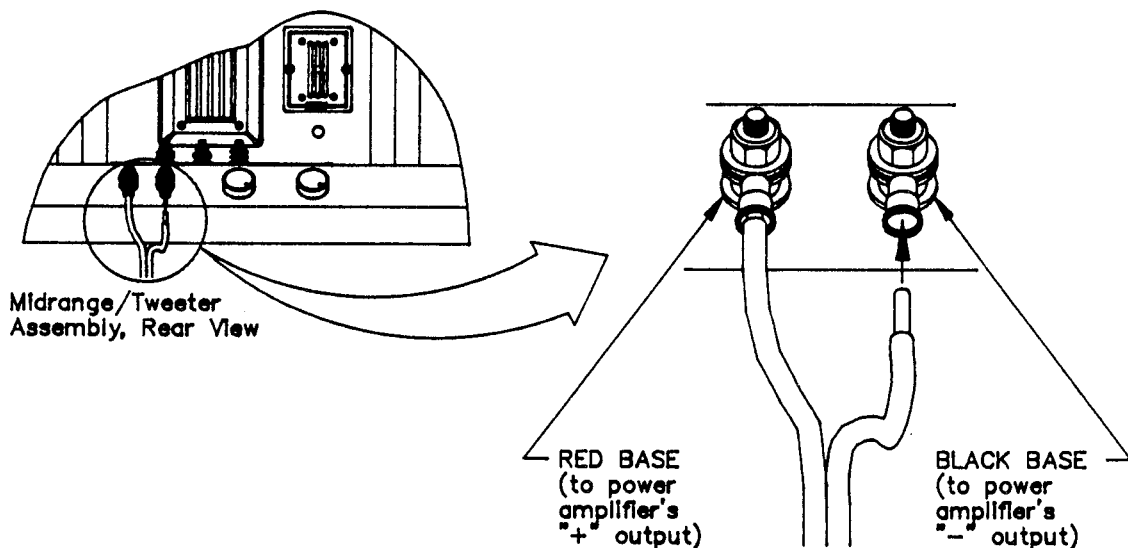

NOTE: If the cables you are using already have ring terminals on them, remove the nuts, washers, and ring terminals from each of the posts and replace the terminals with those on your cables. Replace the washers and nuts; tighten firmly. If desired you may remove the retaining nuts, washers and ring terminals from the posts and solder the ends of your speaker cables directly to the input posts. (Be sure to leave the bottom nuts and colored washers in place.) Use a soldering iron of at least 100 watts, apply a good soldering flux to the posts, then make the connections using some of the solder provided.

Connect each of the 3-prong power cables to the receptacles on each of the woofer tower amplifiers. Plug the other ends into a source of AC voltage that is compatible with the voltage rating of the speaker system. (If extension cords are used, choose only the heavy-duty grounded type.)

CAUTION: At full power the amplifiers are capable of drawing up to twenty amperes each at 120 VAC (One-half as much current at 220 VAC). For this reason it is not advisable to use the same AC circuit for both amplifiers.

Before Operating the System:

A Word About Absolute Phase...

In order to obtain the proper results from the Infinity Reference Standard Series V speaker system, it is essential to maintain absolute phase throughout the entire audio system.

Consider a hypothetical sine wave being fed into two amplifiers, one non-inverting, the other one inverting. The output of the non-inverting amplifier is in-phase with the input signal, however the output of the inverting amplifier is now 180-degrees out-of-phase with the input (hence the term "inverting") (See figure 11).

Figure 11: Non-Inverting and Inverting Amplifiers

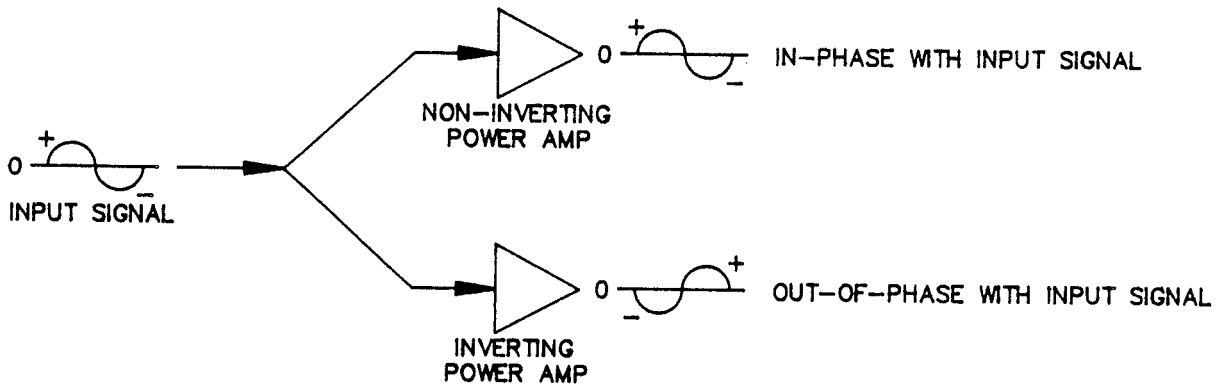

Determine if the components in your audio system are the non-inverting or inverting types. (This information may be obtained from your dealer, or from the components' manufacturers.) The electronic crossover unit and the woofer tower amplifiers in this Infinity Reference Standard Series V system are the non-inverting type.

If all of your components are non-inverting, then maintaining absolute phase will require nothing more than connecting the system normally: "+" to "+", "-" to "-", at all connections. However, if any of your components are the inverting type some changes will be necessary in order to maintain absolute phase.

For example, if your preamp was your only inverting component, the signal would be 180-degrees out-of-phase from the preamp through the rest of the audio chain, until it would finally be reproduced through the speakers (with less than optimum results). To maintain absolute phase two things are necessary:

1. Set the electronic crossover's PHASE switch to the "180-degrees" position. (This corrects the LOW PASS signal only.)
2. Reverse the polarity (+ and -) of the speaker output leads at your mid/tweeter power amplifier(s). (Do not reverse the left and right channels!) (See figure 12.)

Figure 12: Maintaining Absolute Phase With an Inverting Preamp

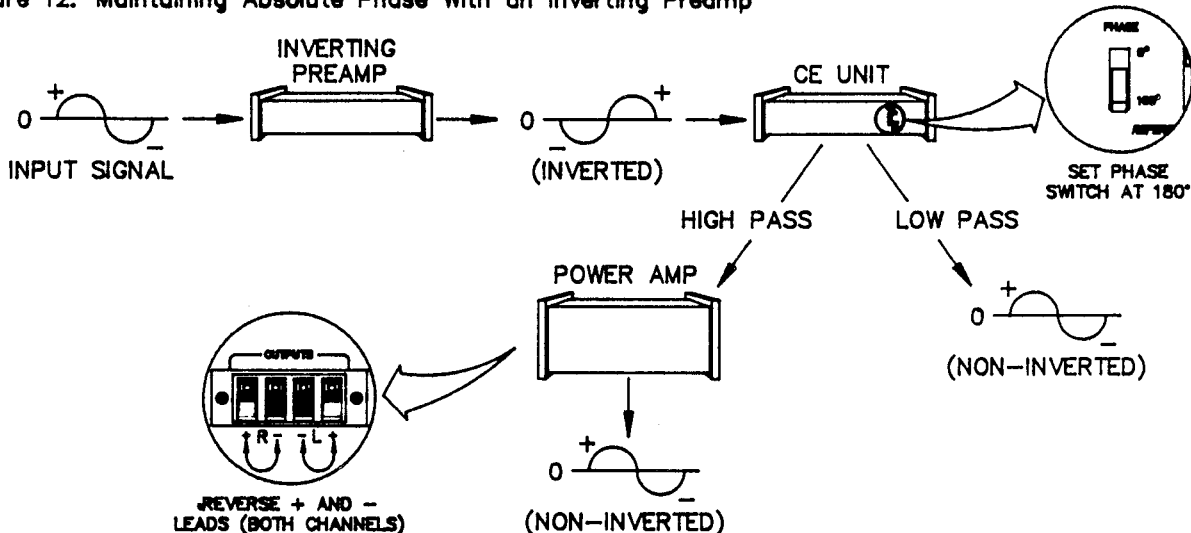

If **BOTH** your preamp and mid/tweeter power amplifier were inverting types (and all of the other components were non-inverting):

Set the electronic crossover's PHASE switch to the "180-degrees" position (to correct the LOW PASS signal.)

(Since the mid/tweeter amplifier is inverting also, the signal will come out of the preamp 180-degrees inverted, then it will re-invert at the outputs of the power amplifier, back to its normal in-phase condition.)

If your mid/tweeter power amplifier is the only inverting component:

Reverse the polarity (+ and -) of the outputs of the power amplifier.

If your turntable employs a head-amp (pre-preamplifier for the cartridge), and that head-amp is an inverting type, reverse the + and - leads at the cartridge. (See figure 13.)

Figure 13: Compensating For an Inverting Head-Amp

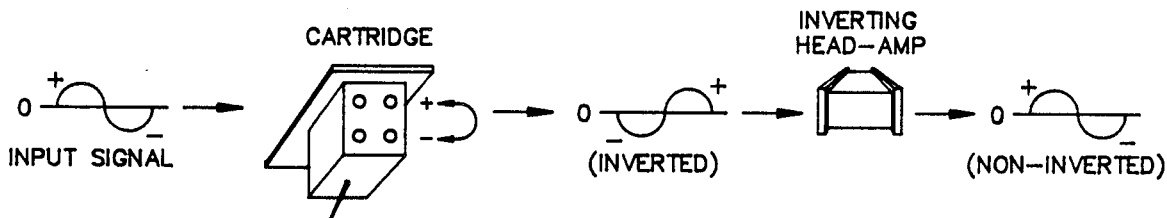

In short, if the number of inverting components that a signal passes through is ODD, the signal will come out 180-degrees out-of-phase (inverted). If the number of inverting components is EVEN or zero, the signal will come out in-phase (non-inverted).

Use the previous guidelines to determine what changes, if any, need to be made in the polarity of the connections in your audio system and make any necessary changes prior to operating the system.

A WORD OF CAUTION...

With high-power systems such as the Infinity Reference Standard Series V, it is essential to protect the system against non-musical signals which could cause damage to the system. For this reason you should **ALWAYS** turn the volume control of your preamp to **MINIMUM** when raising or lowering your turntable's tonearm, or when switching between input sources.

Under no circumstances should you make or break cable connections while the system is turned on.

Operating the System:

Start with all of your audio components plugged in but switched off.

Set the volume control of your preamp to MINIMUM, and all tone controls at their "flat" (center-detent) positions.

Set the controls of the electronic crossover unit as follows:

LOW CUT DEFEAT:	NORMAL
LOW PASS CUTOFF:	NORM
LOW PASS CONTOUR:	NORM
LOW CUT:	22Hz
LOW FREQ LEVEL:	0 (12 o'clock position)
PHASE:	As required to keep the system in absolute phase, as previously discussed

Set the level controls in back of the midrange/tweeter assemblies to the 12:00 (straight-up) position.

Turn on your audio components and allow them proper warm-up time if necessary.

Choose a source of musical input that has a clean, wide signal range, and begin to feed it into your audio system. Slowly turn the volume control up until a comfortable listening level is achieved.

Verify proper speaker connections by turning the balance control of your preamp fully counterclockwise (or, by leaving the left-channel on and reducing the right-channel to minimum); music should now be heard only through the left speakers. Repeat this test for the right (fully clockwise) channel.

With the balance at the center position, adjust the electronic crossover's LOW FREQ LEVEL control until you are satisfied with the balance of bass response to midrange/tweeter levels.

Adjusting the Sound:

While listening to a variety of your favorite recordings, use the controls on the electronic crossover unit (discussed in detail a little further along in this manual) to adjust the low frequency level and tone to best suit your taste and listening environment. Then adjust the upper mid-range and tweeter level controls on the midrange/tweeter sections until you are pleased with the overall blend of sound throughout the audio spectrum. Taking your time, making all adjustments in small increments, will reward you with the most enjoyable listening experience available outside of a concert auditorium.

If, after properly positioning the speaker system, you find the bass response is boomy and lacking tightness, or if you detect a rumbling sound when listening to record albums, or if you notice excessive movement of the woofer cones, the cause may be acoustic feedback. This means that low-frequency vibrations from your speakers are being picked up by the cartridge on your turntable and then fed back into the system. Because of the extended low-frequency response of the Infinity Reference Standard Series V, isolating the turntable from these vibrations calls for considerable care.

In general, place the turntable on a solid, heavy support, as far away from the woofer towers as possible. Some combinations of turntable, tonearm and cartridge are more susceptible to acoustic feedback than others and may require further help to eliminate this problem. If you experience difficulties in this area, your Infinity dealer will be able to provide you with information to help remedy the situation.

If you detect a 50/60-cycle hum in the woofer towers while the LOW FREQ LEVEL control on the electronic crossover unit is at minimum, use a floating adapter on one or both of the woofer tower amplifier power cords.

If hum is noted in the midrange/tweeter sections while the preamp's volume control is at minimum, float the grounds on each of your components, one at a time, until the hum is eliminated. If necessary, float all of the components EXCEPT ONE (to avoid possible shock hazards in the event of an equipment malfunction). Also, inverting the plugs of your two-pronged power cords may eliminate this problem.

If there is hum in the system only while the volume levels are turned up, there is a faulty connecting cable, or a bad chassis ground or loose ground connection in one or more of the components in your audio system. Double-check all connections (especially your turntable's grounding wire) and if necessary replace the connecting cables one at a time with a cable you know to be in proper repair until a defective cable is found.

If hum still presents a problem, contact your Infinity dealer, or Infinity's Customer Service department.

The Electronic Crossover Unit:

Figure 14 shows the front panel of the Infinity Reference Standard Series V electronic crossover unit:

Figure 14: Electronic Crossover Unit, Front Panel

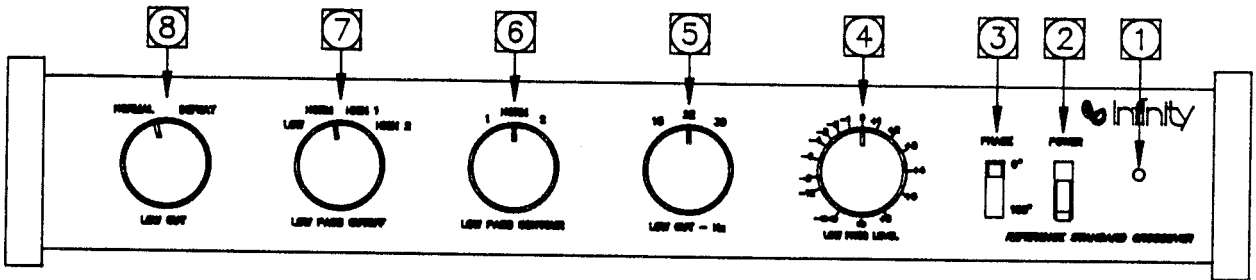

THE FRONT PANEL CONTROLS:

- 1: POWER INDICATOR LED glows when the unit is on.
- 2: POWER SWITCH turns the unit on (up) and off (down). This also turns the woofer tower amplifiers on and off.
- 3: PHASE SWITCH affects the phase of the low pass circuit only: at "0" the low pass output is in-phase with the input signal; at "180" the low pass output is inverted 180-degrees from the input signal. (This is discussed in detail in the section on maintaining absolute phase.)
- 4: LOW FREQ LEVEL adjusts the output level of the woofer towers.
- 5: LOW CUT-HZ determines the low frequency limit of the signal which goes into the woofer tower amplifiers. The "15 Hz" position provides the deepest sub-bass frequencies, but may also promote low-frequency acoustic feedback through your turntable.
- 6: LOW PASS CONTOUR determines the shape of the curve of the low pass filter at its "upper corner" (determined by the setting of the LOW PASS CUTOFF control) as shown in figure 15.

Figure 15: Low Pass Contour Curve Shapes

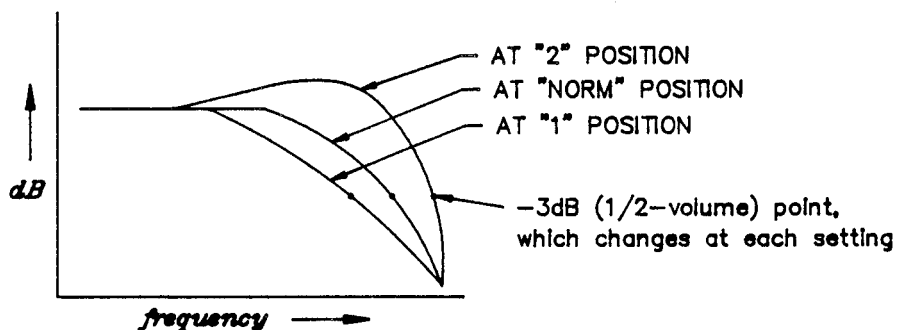

7: LOW PASS CUTOFF determines at which frequency the -3dB (1/2-volume) point of the "upper corner" of the low pass curve occurs, as follows:

LOW:	60Hz
NORM:	74Hz
HIGH 1:	90Hz
HIGH 2:	110Hz

8: LOW CUT DEFEAT works in conjunction with the LOW CUT-HZ control where in the NORMAL position the low-frequency response is -3dB at either 15, 22 or 30 Hz (depending on the setting of the LOW CUT-HZ control). In the DEFEAT position, the acoustic output of the woofer towers still rolls-off at about 15 cycles, however, without the fourth-order attenuation shape it had when the LOW CUT-HZ control was engaged. Now the roll-off has a second-order slope which means much less low-frequency phase shift and envelope delay, resulting in better sound well up into the mid-frequency range. However, record warps and subsonic energy can now more easily cause acoustic feedback and excessive woofer excursion at loud levels.

Use the DEFEAT switch with discretion!

Figure 16 shows the rear panel of the electronic crossover unit.

Figure 16: Electronic Crossover Unit, Rear Panel

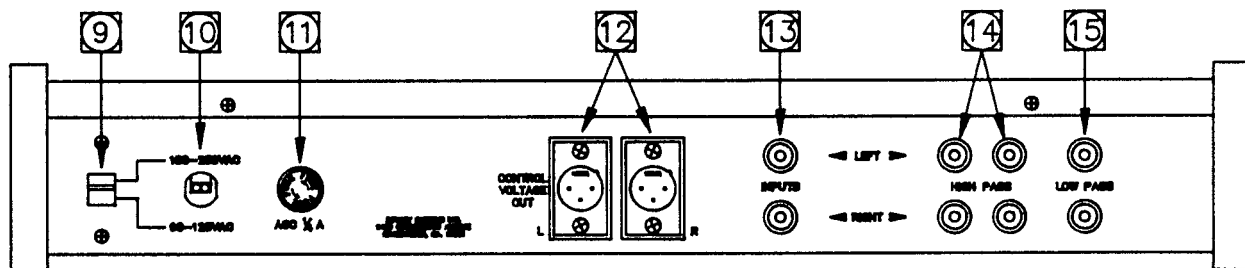

THE REAR PANEL CONTROLS:

- 9: VOLTAGE SELECT SWITCH matches the electronic crossover's power supply transformer to the AC line voltage of the electrical system. The down position is for 90-125 VAC, the up position is for 180-250 VAC. To change the switch, loosen its two screws about 1/2-turn, set the switch in the desired position, then retighten the screws.
- 10: AC LINE CORD plugs into a suitable source of AC line voltage to supply the unit with its AC power.
- 11: FUSE provides protection for the electronic crossover's internal circuitry against power overload conditions. REPLACEMENT OF THE FUSE WITH THAT OF A RATING HIGHER THAN WHAT IS PRINTED ON THE CHASSIS WILL VOID YOUR WARRANTY.

- 12: CONTROL VOLTAGE OUTPUTS connect to the woofer tower amplifiers to supply their remote on/off signals. (Use the cables provided with this system.)
- 13: INPUTS connect from the output jacks of your preamp to supply the electronic crossover unit with its program material.
- 14: HIGH PASS OUTPUTS connect to the input jacks of your mid/high frequency power amplifier(s) to supply the higher-frequency signals.
- NOTE: While there are two sets of HIGH PASS jacks on the electronic crossover unit, only one set is to be used. (It makes no difference which set of left and right jacks you choose.) Leave the other set unused.
- 15: LOW PASS OUTPUT jacks connect to the input jacks of the woofer tower amplifiers (use the cables provided with this system) to supply the low-frequency signals.

Some Features of the Infinity Reference Standard Series Five Speaker System:

The Electronic Crossover Unit

Highest-quality, gold-plated "Tiffany(tm)" signal input and output jacks, mounted on their own PCB to prevent them from coming loose.

A linear low frequency level control calibrated in dB is variable from $-\infty$ to + 6dB gain.

Multiple choices of cut-off frequencies and roll-off shapes.

External input impedance matching devices with WonderCap(tm) capacitors, as well as a supply of all the necessary capacitors and resistors to accommodate the input impedances of virtually any power amplifier.

The Woofer Towers and Their Amplifiers

Twelve twelve-inch woofers with injection-molded graphite cones, acoustically dampened cast-frame baskets, double spiders and long-throw voice coils.

One woofer in each tower has an internal accelerometer connected to a servo circuit in its amplifier to detect and eliminate low-frequency acoustic distortion before it is reproduced through the system.

The high-frequency response of the woofer tower amplifiers extends to almost 1kHz. With the band limiting of the electronic crossover unit being 15 to 110 Hz, the acoustic output of the woofer towers is a very good replica of the low-frequency signal from the audio system.

Each woofer is connected to the outputs of its amplifier with an equal length of Monster Cable(tm) to ensure an equal distribution of power throughout the woofers. (All woofer connections are soldered with Ersin(tm) solder.)

Each woofer tower amplifier has two massive power transformers, large banks of energy-storing capacitors, 14 NPN and 14 PNP output transistors (with forced-air cooling), all of which results in an amplifier capable of delivering 1500-watts into less than one ohm.

The Midrange/Tweeter Sections

Twenty-four Electro-Magnetic Induction Midrange (EMIM) drivers (twelve per channel), wired with Audio Research(tm) cables and soldered with special solder.

Seventy-two Electro-Magnetic Induction Tweeter (EMIT) drivers (thirty-six per channel, twelve per channel facing rearward), wired with Monster Cable(tm) and soldered with special solder.

Highest-quality Solen(tm) and WonderCap(tm) polypropylene capacitors in the passive crossover networks. (All components in the network are held to +/-1% tolerance, and are soldered with special solder.)

Independently adjustable upper midrange and tweeter output level controls.

Crossover frequencies: 100Hz for midranges, 6kHz for tweeters.

Each of the curved pieces are designed to reduce diffraction and are sand-filled to reduce resonance.

Care of the Enclosures:

The Infinity Reference Standard Series V is housed in cabinetry made of choice rosewood solids and veneers. A rich, semi-gloss lacquer is then applied, which requires nothing more than an occasional dusting with a cloth treated with any quality furniture-dusting product. If the finish is ever damaged, have it repaired by a qualified professional furniture refinisher. The top caps and bases are constructed of fiberglass, with a semi-gloss black lacquer finish. A light dusting-off with a soft damp cloth will keep them looking their best. Do not use abrasive or caustic chemicals which would damage the finish.

The grille cloths may be cleaned by gently vacuuming them using a furniture brush attachment or automobile upholstery vacuum cleaner. Do not use cleaning fluids or solvents of any kind as they will damage the cloth.

Infinity Reference Standard Series V
Log Sheet

System Number: _____

Date: _____

Built by: _____

Inspected by: _____

Packed by: _____

Voltage: _____ 120 VAC _____ 220 VAC

Serial numbers:

Amplifiers: _____, _____

Electronic Crossover: _____

Midranges: _____

through _____